

Low-Noise Analog MEMS Microphone and Preamp with Compression and Noise Gating

CIRCUIT FUNCTION AND BENEFITS

This circuit, shown in Figure 1, interfaces an analog MEMS microphone to a microphone preamp. The INMP504 consists of a MEMS microphone element and an output amplifier. Invensense MEMS microphones have a high signal-to-noise ratio (SNR) and a flat wideband frequency response, making them an excellent choice for high performance, low power applications.

The SSM2167 is a low voltage, low noise mono microphone preamp that is a good choice for use in low power audio signal chains. This preamp includes built-in compression and noise gating, which gives it an advantage for this function over using just an op amp in the preamp circuit. Compressing the dynamic range of the microphone signal can reduce the peak signal levels and add additional gain to low level signals. Noise gating attenuates the level of signals below a certain threshold, so that only desired signals, such as speech, are amplified, and noise in the output signal is reduced. These features help to improve the intelligibility of the voice signal picked up by the microphone.

CIRCUIT DESCRIPTION

The INMP504 analog MEMS microphone is connected to the SSM2167 INPUT pin through a 0.1 μF capacitor. This coupling capacitor is necessary because the microphone's output is biased at 0.8 V, and the preamp's input is biased at 0.4 V. The preamp's input and the ac coupling capacitor between the microphone and preamp input form a high-pass filter.

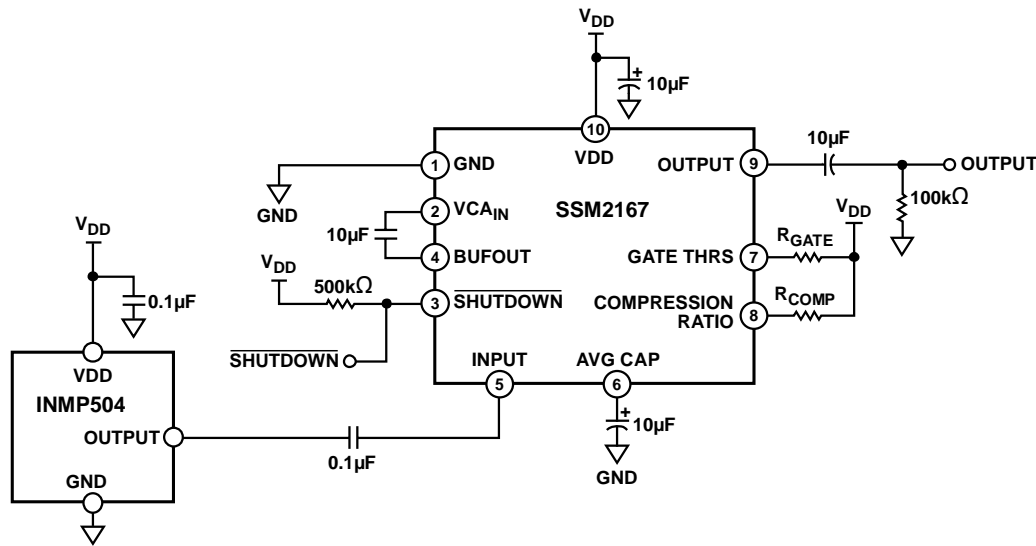

Figure 1. Analog MEMS Microphone Connection to Preamp

The -3 dB corner frequency of this filter is $1/(2\pi RC)$, where C is the capacitor size, and R is the preamp's input impedance (100 k Ω). For a 0.1 μF coupling capacitor, the high-pass filter's corner is 16 Hz. Increasing the capacitor size will lower the filter corner frequency.

The time constant of the SSM2167's true rms level detector is controlled by the size of the capacitor connected to AVG CAP (pin 6). A 10 μF capacitor results in a time constant of about 100 ms, which is a reasonable setting for speech signals. This time constant controls the rms detector's averaging, as well as the compressor's release time. A smaller capacitor used here will give a shorter time constant, and a larger capacitor will result in a longer time constant. The time constant in milliseconds is calculated by $10 \times C_{AVG}$, where C_{AVG} is in μF .

Both the microphone and the preamp can be powered from a single 2.5 V to 3.3 V supply. The SSM2167 preamp requires some additional external passive components for its operation:

- 10 μF capacitor between V_{DD} and ground
- 10 μF capacitor between pins VCA_{IN} and BUF_{OUT}
- AC coupling capacitor on OUTPUT pin
- 500 k Ω pull-up resistor on SHUTDOWN pin
- R_{GATE} : sets the threshold of the noise gate
- R_{COMP} : sets the compression ratio

The INMP504 has a -38 dBV sensitivity, which means that an input signal of 94 dB SPL (1 Pascal) will be output from the microphone at -38 dBV. This microphone’s maximum input level is 120 dB SPL, at which level its output will be -12 dBV. Its dynamic range is 91 dB, so the microphone’s noise floor is at -103 dBV.

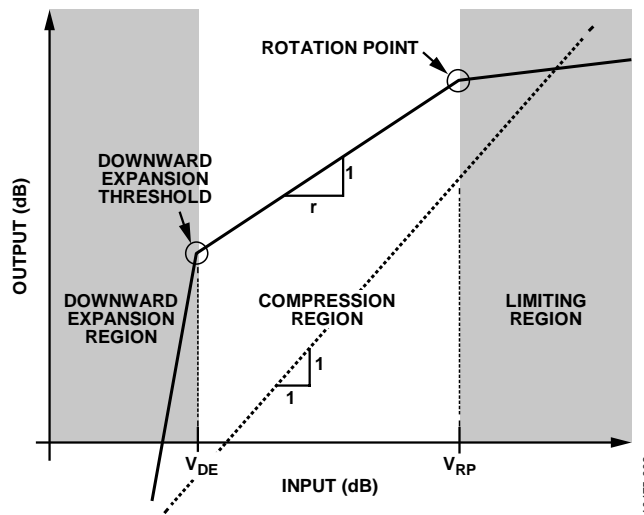

Figure 2. Gain Regions

Gain is applied to the SSM2167 input signal in three different regions—downward expansion, compression, and limiting, as shown in Figure 2. The SSM2167 applies a fixed 18 dB of gain to input signals and can also apply an additional variable gain to signals between the downward expansion point and rotation point.

The downward expansion threshold is the boundary between the downward expansion and compression regions. This point is set by the selection of resistor R_{GATE} (Table 1). The threshold can be set at a point for input signals between 77 dB and 92 dB SPL, or -55 dBV to -40 dBV input to the preamp.

Table 1. Noise Gate Threshold Settings

Preamp Noise Gate Threshold (dBV)	Microphone (dB SPL)	R_{GATE} (k Ω)
-40	92	0 (short to V_{DD})
-48	84	1
-54	78	2
-55	77	5

The compression region lies between the downward expansion and limiting regions. In this region, the dynamic range of the input signal can be reduced, or compressed, so that the output signal level is more smooth and constant. The SSM2167 can achieve compression ratios of up to 10:1. This downward compressor will increase the level of the signal below the rotation point threshold. The level of compression is controlled by resistor R_{COMP} , as detailed in Table 2.

Table 2. Compression Ratio Settings

Compression Ratio	R_{COMP} Value (k Ω)
1:1	0 (short to V_{DD})
2:1	15
3:1	35
5:1	75
10:1	175

The boundary between the compression and limiting regions is fixed at a -24 dBV preamp input signal level, which corresponds to a 108 dB SPL acoustic input to the microphone. Above this point, after the 18 dB of fixed gain, the preamp output will be limited to a -6 dBV level.

Figure 3 shows the voltage output levels vs. acoustic input levels of the circuit for a selection of different compression ratios.

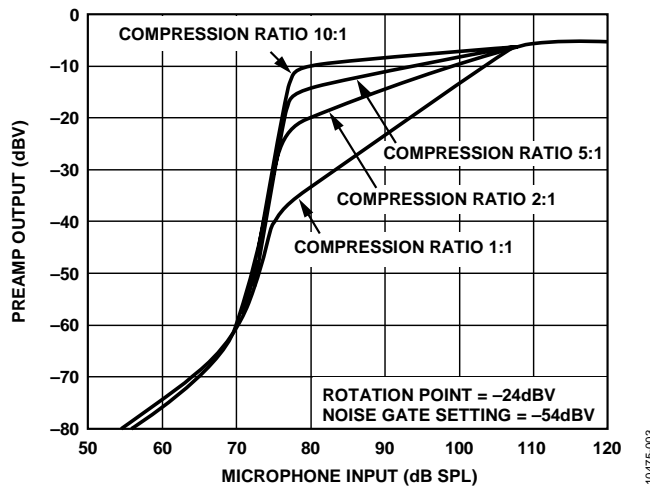

Figure 3. Circuit Output vs. Input Characteristics

The SSM2167 output is biased at 1.4 V. The 10 μ F ac-coupling capacitor in series with the output signal allows the output to be connected to grounded loads. The 100 k Ω resistor references the back side of the coupling capacitor to ground to avoid pops when loads are hot-plugged. This resistor is not necessary in a design where the load is hardwired to the preamp's output.

Noise Performance

Both the INMP504 and SSM2167 are low noise audio devices. The INMP504 SNR is 65 dB, which gives a -103 dBV noise floor. The noise floor of the SSM2167 with 10:1 compression (worst-case setting for noise) is -70 dBV. So, the microphone signal’s noise level can be increased by more than 20 dB before combining the noise floors of the two devices results in a degradation of the overall system noise floor. For example, a loud 100 dB SPL signal output picked up by the microphone with the preamp set to a 10:1 compression ratio will have about 24 dB of gain added to the system. This will put the microphone signal’s noise floor at -79 dBV (-103 + 24). Combining a -79 dBV noise source with the -70 dBV noise floor of the preamp will result in degradation in the system of only about 0.5 dB, so the noise floor of the output signal in these conditions is about -69.5 dBV.

When the microphone’s output signal is at a level below the downward expansion threshold, a fixed 18 dB gain will be applied to the signal, which will keep the signal’s noise floor well below the noise floor of the SSM2167.

COMMON VARIATIONS

This circuit can also be set up with the SSM2166 instead of the SSM2167. The SSM2166 is a more flexible, but more expensive, preamp. The rotation point and VCA gain on the SSM2166 can be adjusted with external components, while these settings are fixed on the SSM2167. The SSM2166 also has a lower noise floor than the SSM2167 and is provided in a larger package (14-lead SOIC_N).

The INMP504 could also be replaced with the INMP401, INMP404, or INMP405. These three MEMS microphones have a 62 dB SNR, while the SNR of the INMP504 is 65 dB. The INMP401 has a -42 dBV sensitivity, while the INMP504, INMP404, and INMP405 have a -38 dBV sensitivity. The INMP405 is identical to the INMP404 except that it has a low frequency cutoff at 200 Hz vs. the INMP404’s 100 Hz cutoff. This higher frequency cutoff makes the INMP405 attractive for reducing low frequency wind noise. The INMP404 and INMP405 are also pin-compatible with the INMP504.

CIRCUIT EVALUATION AND TEST

Evaluation boards for the INMP504 (EV_INMP504-FX) and SSM2167 (SSM2167Z-EVAL) are available and can easily be connected as described below.

The EV_INMP504-FX has three output wires: -VDD (red), ground (black), and output (white). The VDD wire should be connected to the +3 V test point of JP3 on the SSM2167 board; power is also supplied to the preamp board at this point. The ground wire can be connected to GND of JP3. The output wire of the INMP504 board can either be connected directly to the JP2 pin or to the tip of a mono 3.5 mm audio plug, with ground connected to the ring. This plug connects to the SSM2167’s evaluation board input jack J1.

Resistor R4 should be removed from the SSM2167 evaluation board. This resistor is used to supply power to electret microphones, but is not needed for MEMS microphones that are powered through a separate VDD pin. From this point, follow the documentation for the SSM2167Z-EVAL in application note AN-583 regarding board setup and listening tests. The documentation for the SSM2167 evaluation board (SSM2167Z-EVAL) describes the system setup and gives a complete schematic of the board. The only external connections required are the +3 V power and audio input and output on J1 and J2, respectively.

REVISION HISTORY

REVISION DATE	REVISION	DESCRIPTION
02/22/2014	1.0	Initial Release

Compliance Declaration Disclaimer:

InvenSense believes this compliance information to be correct but cannot guarantee accuracy or completeness. Conformity documents for the above component constitutes are on file. InvenSense subcontracts manufacturing and the information contained herein is based on data received from vendors and suppliers, which has not been validated by InvenSense.

Environmental Declaration Disclaimer:

InvenSense believes this environmental information to be correct but cannot guarantee accuracy or completeness. Conformity documents for the above component constitutes are on file. InvenSense subcontracts manufacturing and the information contained herein is based on data received from vendors and suppliers, which has not been validated by InvenSense.

This information furnished by InvenSense is believed to be accurate and reliable. However, no responsibility is assumed by InvenSense for its use, or for any infringements of patents or other rights of third parties that may result from its use. Specifications are subject to change without notice. InvenSense reserves the right to make changes to this product, including its circuits and software, in order to improve its design and/or performance, without prior notice. InvenSense makes no warranties, neither expressed nor implied, regarding the information and specifications contained in this document. InvenSense assumes no responsibility for any claims or damages arising from information contained in this document, or from the use of products and services detailed therein. This includes, but is not limited to, claims or damages based on the infringement of patents, copyrights, mask work and/or other intellectual property rights.

Certain intellectual property owned by InvenSense and described in this document is patent protected. No license is granted by implication or otherwise under any patent or patent rights of InvenSense. This publication supersedes and replaces all information previously supplied. Trademarks that are registered trademarks are the property of their respective companies. InvenSense sensors should not be used or sold in the development, storage, production or utilization of any conventional or mass-destructive weapons or for any other weapons or life threatening applications, as well as in any other life critical applications such as medical equipment, transportation, aerospace and nuclear instruments, undersea equipment, power plant equipment, disaster prevention and crime prevention equipment.

©2014 InvenSense, Inc. All rights reserved. InvenSense, MotionTracking, MotionProcessing, MotionProcessor, MotionFusion, MotionApps, DMP, AAR, and the InvenSense logo are trademarks of InvenSense, Inc. Other company and product names may be trademarks of the respective companies with which they are associated.



©2014 InvenSense, Inc. All rights reserved.