

AH-20166-045045 Acoustic Housing Brief

GENERAL INFORMATION

The AH-20166-045045 is a symmetrical horn that is available for the CH201 ultrasonic sensor that modifies the field of view to 45 degrees in both the horizontal and vertical plane.

DEVICE INFORMATION

Part Number	Type	Diameter (mm)		Length (mm)	Field Of View (FoV)	
		Horizontal	Vertical		Horizontal	Vertical
AH-20166-045045	Exponential	6	6	2.9	45	45

- CAD file for 3D printing of AH-20166-045045 is available from Chirp Microsystems.
- Recommendations for adhesives, gluing instructions, 3D printing guidelines, and basic verification after installation of AH-20166-045045 see document AN-000223.

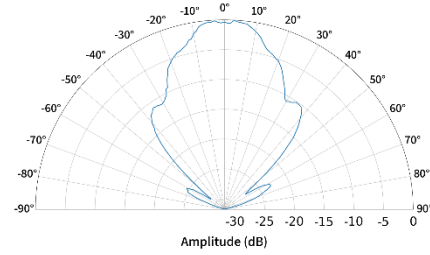
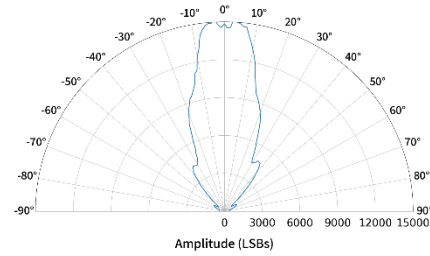

Figure 1: AH-20166-045045 Beam Patterns

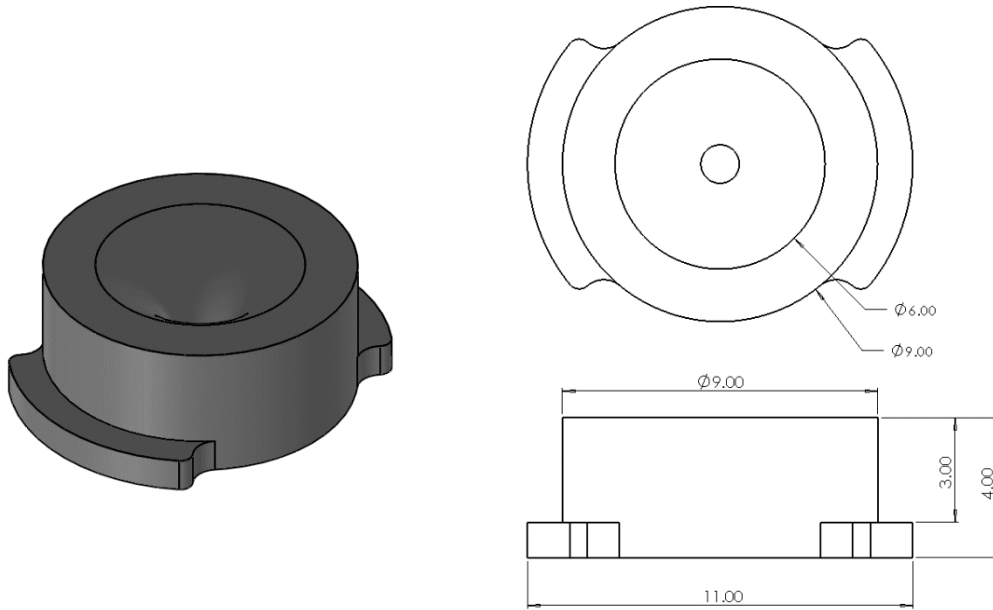

Figure 2: AH-20166-045045 Acoustic Horn Drawing