

**TDK InvenSense**

**IMU PCB Design and MEMS Assembly  
Guidelines**

**for**

**ICM/IAM/IIM-4xxxx, 2xxxx and MPU-6xxx  
Products**



# TABLE OF CONTENTS

1	Introduction.....	5
2	PCB Design Guidelines .....	6
2.1	General PCB Guidelines .....	6
2.2	PCB Land Pattern .....	6
2.3	Solder Paste Printing .....	8
2.4	Routing .....	10
2.5	Flex PCB .....	11
3	PCB PLACEMENT AND BOARD MOUNTING Guidelines .....	12
3.1	General Recommendations .....	12
3.2	PCB anchor points .....	12
3.3	Mechanical stress on PCB.....	13
3.4	PCB with over hanging beam.....	13
3.5	Buttons, Pogo Pins, shielding boxes, connects, etc. ....	13
3.6	Thermal requirements.....	14
3.7	Speakers, fans, etc. ....	15
3.8	Shock and vibration .....	15
3.9	Epoxy-Seal and other material .....	16
3.10	Edge of PCB.....	17
4	IMU Products Handling guideline .....	18
4.1	MEMS handling instructions.....	18
4.2	IMU Products ASSEMBLY guidelines.....	18
4.3	ESD Considerations.....	18
4.4	Reflow Specification .....	19
4.5	Storage Specifications .....	19
4.6	Tape and Reel Handling Instructions .....	19
4.7	Tape and Reel Packaging .....	20
5	Revision history .....	25
	Figure 1. NSMD and SMD .....	7
	Figure 2. Recommended PCB Layout footprint for IMU Products in LGA package .....	7
	Figure 3. Recommended PCB Layout footprint for IMU Products in QFN and DQFN package .....	8
	Figure 4. Stencil opening dimensions .....	9
	Figure 5. Pre and post reflow configuration .....	9
	Figure 6. Symmetrical trace out .....	10
	Figure 7. Keep distance from high-speed and high current traces .....	10

Figure 8. Avoid traces, vias and copper pour below IMUs .....	11
Figure 9. PCB anchor points .....	13
Figure 10. Keep away from anchor points and the intersection of anchor points .....	13
Figure 11. Avoid place IMU Products on long hanging beam.....	13
Figure 12. Avoid connectors directly behind the board.....	14
Figure 13. Keep distance from heat sources .....	14
Figure 14. Speaker and Tactile Vibrations can be interpreted as Noise by the IMUs .....	15
Figure 15. Keep distance to high frequency Electrical sources .....	15
Figure 16. Keep distance from epoxy coating.....	16
Figure 17. Panelized PCB Bridges .....	17
Figure 18. Reel Outline Drawing .....	20
Figure 19. Barcode Label.....	20
Figure 20. Location of Label on Reel .....	21
Figure 21. Barcode Label on the Left of the Box .....	21
Figure 22. REEL Packing.....	21
Figure 23. MSL Label (MSL 1, MSL 3 and MSL 5) .....	22
Figure 24. Reel Packing for shipping .....	22
Figure 25. Labels .....	23
Figure 26. Boxes and Labels .....	23
Figure 27. Outer Shipping Carton Label .....	24

## **1 INTRODUCTION**

This document provides high-level PCB design, sensor mounting, and handling guidelines for TDK IMU Products, which incorporate a combination of gyroscopes and accelerometers. Each sensor has specific requirements to ensure the highest performance in a finished product. For a layout assessment of your design, including placement and estimated temperature disturbances, please contact TDK.

The TDK IMU Products discussed in this document consist of 3-axis MEMS gyroscopes and 3-axis MEMS accelerometers.

This document replaces AN-IVS-0002A-00 MEMS Motion Handling and Assembly Guide.

## 2 PCB DESIGN GUIDELINES

### 2.1 GENERAL PCB GUIDELINES

- Non-Solder Mask Defined pads (NSMD) are recommended more than Solder Mask Defined (SMD) pads.
- Traces connected to pads should be as symmetrical as possible.
- Avoiding vias, traces, and copper pour under all the layers below the IMU Products is recommended.
- Always place VDD decoupling capacitors as close as possible to the VDD pin. The VDD pin fanout trace should be thicker than 6 mil. The noise level on the VDD must meet datasheet specifications.
- Always place VDDIO decoupling capacitors as close as possible to the VDDIO pin. The VDDIO pin fanout trace should be thicker than 6 mil.
- VDD and VDDIO can be from same power supply source, but each should have its own decoupling capacitor.
- Keep VDD, VDDIO, serial communication lines away from any battery charge and from components and signals related to the DC-DC switching power regulator when doing the layout. The high energy of a power signal can generate a lot of noise or spikes.
- Provide solid GND connections for GND pin (pin6). Any nearby GND via must be bigger than 8 mil drill and 12 mil copper. Multiple nearby GND vias are recommended for solid GND connections. The GND pin fanout trace should be thicker than 6 mil.
- Reduce serial communication bus capacitance by avoiding long trace. Always balance the bus lines as close as possible to trace length.
- For high-speed interfaces, such as I<sup>2</sup>C, I3C, and SPI, all clock and data traces should be routed with the same length and away from other high-speed traces. Power traces should also be routed away from high-speed signals.
- TDK InvenSense IMU Products provide configurations for output pad slew rate (drive strength) adjustment. User can adjust the output pad slew rate to optimize signal integrity on PCB board. Stronger drive strength is recommended for long PCB trace or long jump wire connections. Do not apply unnecessary strong drive strength to avoid over/under shoot on signal. We recommend adjusting the slew rate setting by using scope to monitor the signals.

### 2.2 PCB LAND PATTERN

For the solder mask of each pin, Non-Solder Mask Defined pads (NSMD) are recommended more than Solder Mask Defined (SMD) pads. NSMD contact pads have the solder mask pulled away from the solderable metallization. NSMD contact pads have several advantages over SMD pads. They provide a tighter tolerance for copper etching, provide a larger copper pad area, and allow the solder to anchor to the edges of the copper pads, which improves solder joint reliability.

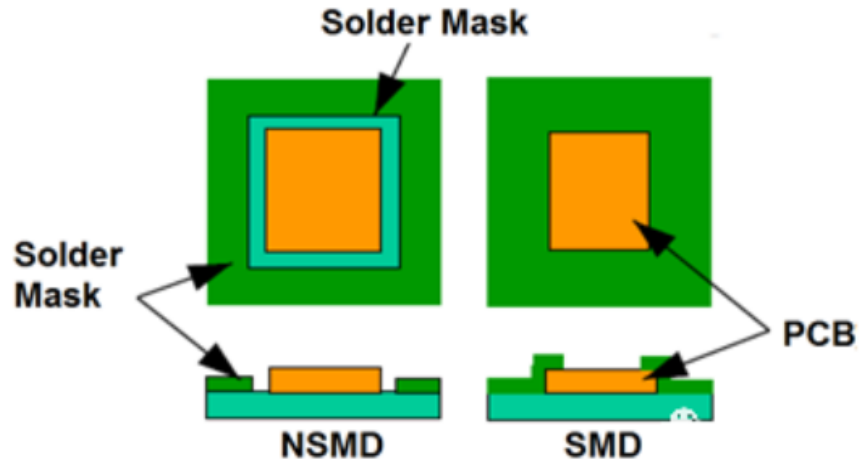
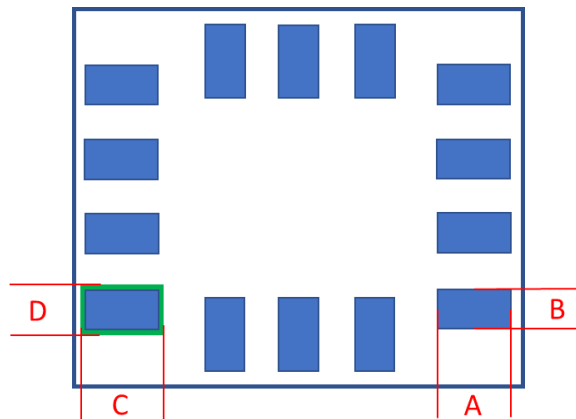

Figure 1. NSMD and SMD

To achieve optimal performance of MEMS motion devices, placing the solder mask below the MEMS component is not recommended. If this is not possible, placing the solder mask below the component will still work.

IMU Product package dimensions are provided in datasheets.

Figure 2 provides PCB land pattern recommendation for IMU Products in LGA package.



- A = PCB land length = LGA solder pin length
- B = PCB land width = LGA solder pin width
- C = Solder mask opening length = PCB land length + 0.1 mm
- D = Solder mask opening width = PCB land width + 0.1 mm

Figure 2. Recommended PCB Layout footprint for IMU Products in LGA package

Figure 3 provides PCB land pattern recommendation for IMU Products in QFN and DQFN package.

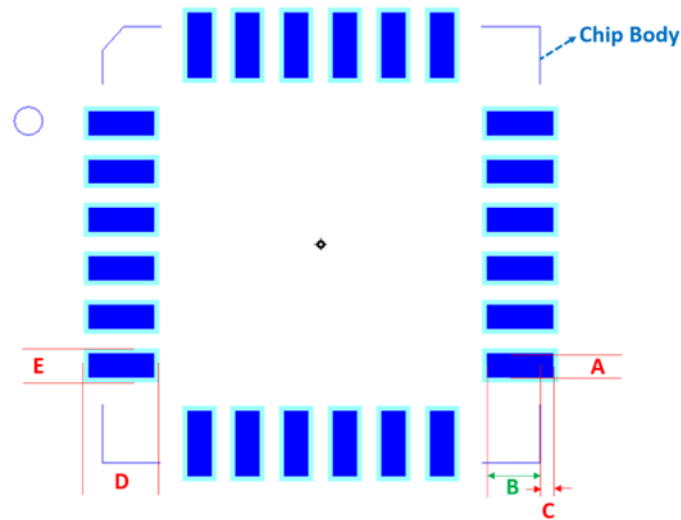

- A = PCB land width = QFN solder pin width
- B = QFN solder pin length
- C = PCB land length extension = 0.15mm
- PCB land length = B + C
- D = Solder mask opening length = PCB land length + 0.1mm
- E = Solder mask opening width = PCB land width + 0.1mm

**Figure 3. Recommended PCB Layout footprint for IMU Products in QFN and DQFN package**

TDK InvenSense products have very low active and standby current consumption. The exposed center pad is not internally connected, and it is not required for heat sinking. The exposed center die pad must not be soldered to the PCB and must be left unconnected.

Please use the most recent revision of the datasheet for the device with which you are working. Dummy traces can be added on unused pins.

### 2.3 SOLDER PASTE PRINTING

Mechanical decoupling from the PCB to the sensor must be ensured to prevent any stress on the component. Contact from PCB resist and the package exposed pad must be avoided. Proper thickness definition for both solder paste and copper help set proper clearance below the package. No solder paste needs to be disposed below the exposed pad.

Solder paste disposition should be done by stencil screening. In standard conditions, TDK InvenSense recommends using a stencil opening to land ration of 90%. Stencil walls should be tapered to produce uniform release of the paste when the stencil is removed from the PCB. Stencil thickness should be at least 100  $\mu\text{m}$  in respect to standard area ratio design rule.



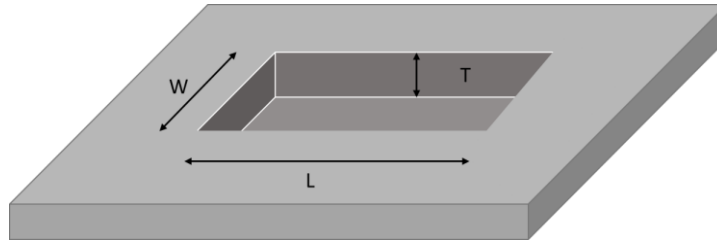

**Figure 4. Stencil opening dimensions**

Generic best practices for stencil design should be followed:

- Aspect Ratio
  - The width of aperture / thickness =  $W/T$
  - The lowest acceptable aspect ratio is 1.5
- Area Ratio
  - Surface area of aperture / surface area of the aperture walls =  $(L \times W) / (2 \times (L+W) \times T)$
  - The lowest acceptable area ratio is 0.66

Maximizing symmetry and balance for pad connection will help with component self-alignment and will lead to better control of solder paste reduction after reflow. At the end of the soldering process, the solder paste must be as uniform as possible to avoid unbalanced stress on the component.

Solder paste volume to be printed is greater than the final solder joint volume because solder paste decreases during reflow. Solder paste volume reduction factor is typically between 0.45 and 0.55. Being the pad area constant, in the worst case, the solder paste thickness can be assumed to be about 45% after the reflow:

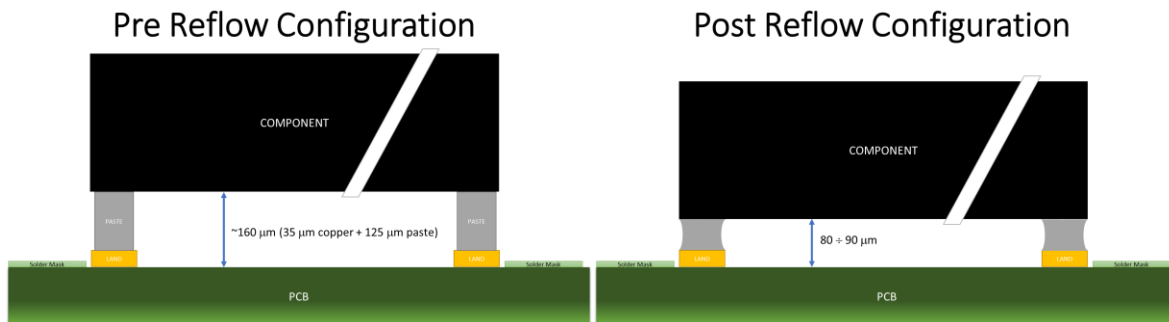

**Figure 5. Pre and post reflow configuration**

## 2.4 ROUTING

Traces connected to pads should be as symmetrical as possible. Symmetry and balance for pad traces will improve component self-alignment and lead to better control of solder paste reduction after the reflow process.

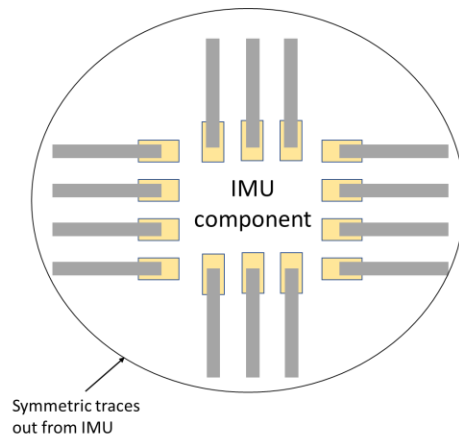

**Figure 6. Symmetrical trace out**

For high-speed interfaces, such as I<sup>2</sup>C, I3C, and SPI, all clock and data traces should be routed with the same length, and away from other high-speed traces. Power traces should also be routed away from high-speed signals. Keep VDD, VDDIO, serial communication lines away from any battery charge and DC-DC switching power regulator related components and signals when doing the layout. The high energy of a power signal can generate a lot of noise or spikes.

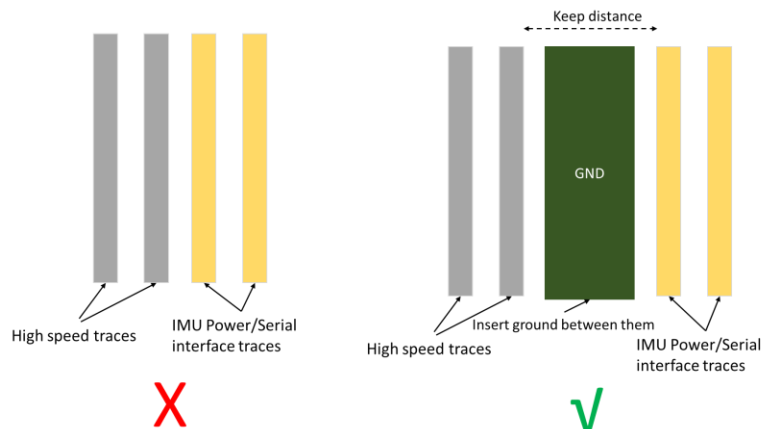
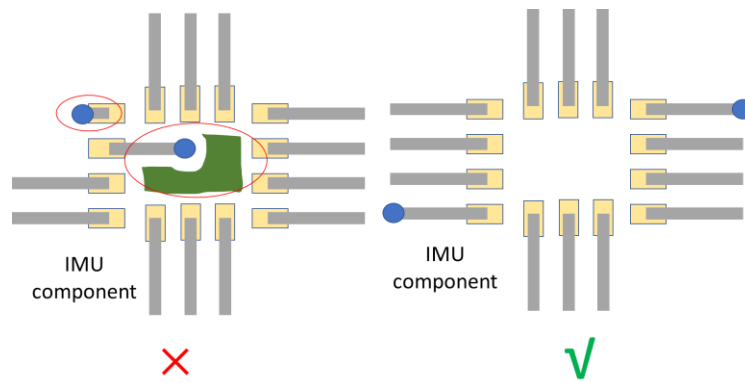

**Figure 7. Keep distance from high-speed and high current traces**

We recommend 6mil or thicker traces for a 0.5 oz or 1 oz copper PCB. Provide a solid ground return path, with traces 10mil or thicker for a 0.5 oz or 1 oz copper PCB. Do not use small vias for power and GND traces.

Trace, via, and filled copper are not allowed under the IMU chip directly, as they can cause elevation changes.

Do not place vias within the pad outline because vias and their related plating materials can contribute to an orientation offset and non-uniform mechanical package stress.



**Figure 8. Avoid traces, vias and copper pour below IMUs**

NC (No Connect) pins should be soldered to the board for mechanical stability, but those pads on the board should not be connected electrically.

## 2.5 FLEX PCB

Flex PCB should be avoided for MEMS sensor parts. If flex PCB must be used, a stiffener must be provided on the opposite side of the flex PCB. The thickness of the stiffener depends on its material. The goal is to prevent the flex PCB from bending, which will generate mechanical stress to MEMS.

### 3 PCB PLACEMENT AND BOARD MOUNTING GUIDELINES

MEMS accelerometer and gyroscope sensors are general high accuracy motion measurement devices. TDK IMU Products are designed with precision, efficiency, and mechanical robustness. However, to achieve highest possible accuracy, the following recommendations should be considered when mounting IMU Products on a printed circuit board (PCB).

#### 3.1 GENERAL RECOMMENDATIONS

- PCB should be installed with 3 anchor points; 2 anchor points or more than 3 is not recommended.
- The IMU Products should be placed on a location that minimizes mechanical stress. Keeping away from the connection of two anchor points is strongly recommended.
- The IMU Products should be kept a reasonable distance to the critical points: e.g., away from any fixed mounting location, screw hole, large insertion components, such as buttons, shielding boxes, connectors, etc.
- To avoid dynamic mechanical stress on pogo pins, placing the sensor direct under or next to pogo pins is not recommended.
- Keeping a reasonable distance between sensor and heat sources, which may include processors, power management circuitry, or high current devices, is recommended.
- Direct epoxy contact on the IMU Products is forbidden. The epoxy-seal should be placed a reasonable distance away from sensor.
- Keep a reasonable distance from the IMU Products to the edge of PCB or bridges for PCB separation by router. Deflection from a routing drill or saw can damage the MEMS device.
- Keeping a reasonable distance from vibration sources, such as speakers, vibration/haptic motors, fans, etc. is recommended.
- The MEMS device can be damaged when shock level is over the datasheet specification. Shock or impact should be avoided in manufacturing flow or device assembly process. It is not recommended to mount the sensor in areas where resonant amplitudes of the PCB are likely.

#### 3.2 PCB ANCHOR POINTS

In theory, an ideal flat plane is determined by 3 anchor points. Two anchor points or more than 3 anchor points should be avoided. If 3 or more anchor points are used, removing any redundant PCB anchor points is recommended.

Figure 9 shows different anchor scenarios. Two anchor points are expected to be unstable. The PCB may shake from any movement or vibration and is expected to have PCB bending. Four or more anchors are assumed not exactly in plane. Removing the redundant anchor point can minimize mechanical stress significantly.

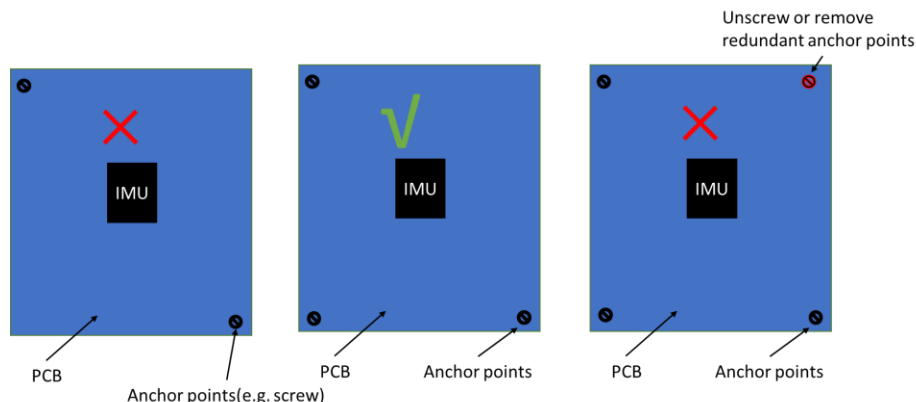

Figure 9. PCB anchor points

### 3.3 MECHANICAL STRESS ON PCB

Keeping a reasonable distance to the mechanical stress maximum point is recommended. As shown in Figure 10, keep away from the intersection of diagonal lines. Keeping away from any PCB anchors is strongly recommended. Keeping a distance larger than 3 mm to any PCB anchor is recommended.

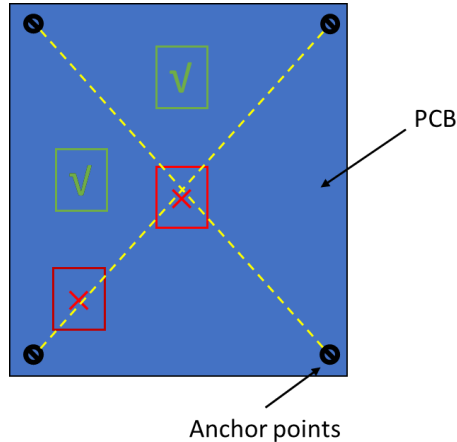

Figure 10. Keep away from anchor points and the intersection of anchor points

### 3.4 PCB WITH OVER HANGING BEAM

Avoid placing the IMU chip on the end of long hanging beam or the PCB with large span. The vibrations are very likely to be happen there. Keeping a reasonable distance is very important to avoid unexpected behavior from the MEMS component.

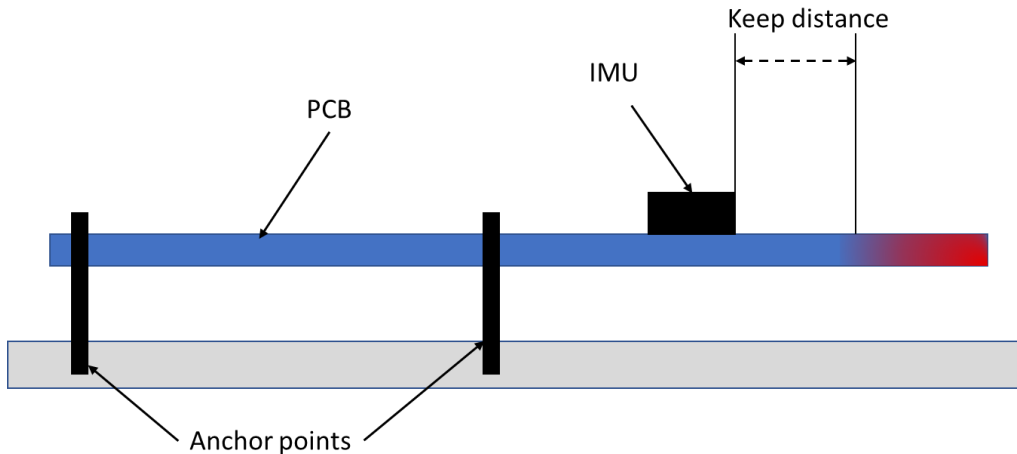

Figure 11. Avoid place IMU Products on long hanging beam

### 3.5 BUTTONS, POGO PINS, SHIELDING BOXES, CONNECTS, ETC.

Do not place connectors or test points for pogo pins on the PCB surface below the IMU Product location, as shown in Figure 12. Shock from snapping the connectors and pressure from the pogo pin during functional test on a production line may damage the MEMS part.

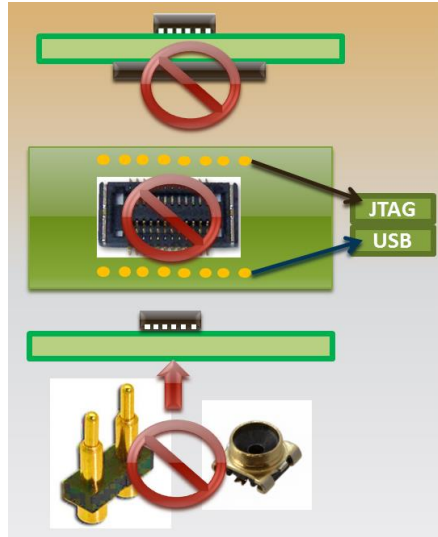

Figure 12. Avoid connectors directly behind the board

### 3.6 THERMAL REQUIREMENTS

Keeping a distance between the heat sources and IMU device is recommended to achieve a higher accuracy measurement. Do not place any heat source component on the opposite side of PCB under IMU device.

The heat sources may include processors, power management circuitry, or high current devices. The temperature gradient across the IMU device, especially the top to bottom gradient should be minimized for best measurement results. Refer to Figure 13.

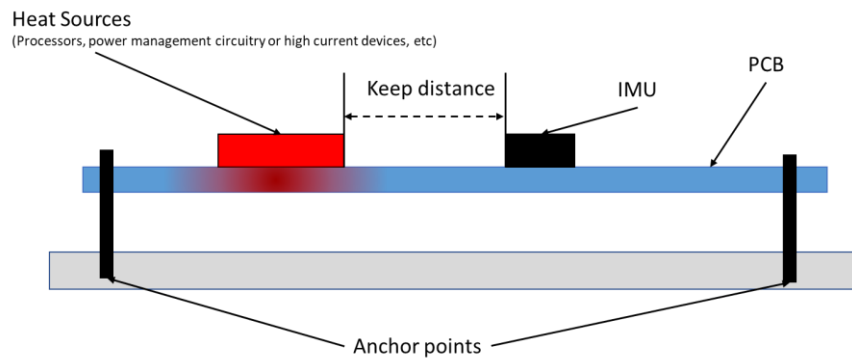
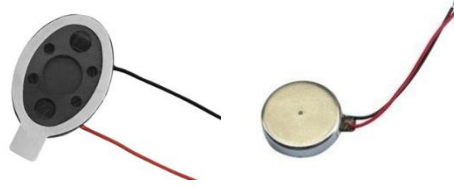

Figure 13. Keep distance from heat sources

### 3.7 SPEAKERS, FANS, ETC.

Moving parts that cause vibration and are not intended to be measured, such as speakers, vibration/haptic motors, fans, etc. (Figure 14), should be mechanically isolated from IMUs.



**Figure 14. Speaker and Tactile Vibrations can be interpreted as Noise by the IMUs**

Active signals may harmonically couple with the gyro MEMS devices, compromising gyro response. TDK IMU gyroscopic sensors operate at drive frequencies 25 kHz ~ 29 kHz. To avoid harmonic coupling, do not route active signals directly below or near the package. If the IMU device is stacked under an adjacent PCB board, design a ground plane to shield the IMU device from the adjacent PCB.

Electrical sources, such as a switched-mode power supply (SMPS) as shown Figure 15, can cause high frequency vibration. SMPS (switched mode power supply) with switching noise below 150 kHz (including Harmonics) can reduce device performance.

As mentioned in section 3.4, in addition to unwanted IMU device vibration output, mechanical vibration can damage MEMS if the vibration frequency matches the MEMS resonant frequency.

Place any acceleration or vibration sources as far away as possible from MEMS devices. If placement is uncertain, consult the local FAE to provide a more detailed analysis.



**Figure 15. Keep distance to high frequency Electrical sources**

### 3.8 SHOCK AND VIBRATION

The MEMS device can be damaged when shock level is over datasheet specification. Shock or impact should be avoided in manufacturing flow or device assembly process.

During the design phase the IMU device should be placed in the location where it will receive the least amount of shock possible. Various measurements can be taken to reduce shock transfer, such as location of the IMU device, shock absorbing washers/gaskets for screw points, and shock absorbing foam pads. From a systems level, the placement of other PCBs/Modules/Sub-systems should be placed away from the top/bottom of where the IMU device is located, to prevent possible contact.

If there are concerns regarding a system level design, the systems should be tested with the IMU device as a whole system or tested beforehand and double checked to ensure there is no damage to the IMU device.

MEMS gyro and accel have multiple internal resonance points. System level designs should avoid vibrations with the same frequency of IMU device resonances. Please consult TDK technical support for each device's resonant frequency.

The TDK InvenSense IMU gyroscope sensors operate at specific drive frequencies. Please refer to each part's datasheet for the exact drive frequency number. Any vibration within these frequency ranges will cause extra gyro

noise or even damage the gyro.

The most common PCB board level vibration source is from power circuits such as a wireless charger, and buck and boost power regulation circuits. Powered devices that may generate acceleration or vibration to the MEMS structures can cause damage to MEMS devices. Examples of such components are inductors, capacitors, PMIC, haptic motors, speakers, etc.

The shock experienced from a PCB level versus device level may and will be different. To attain the most accurate data reading, the measurements should be taken from a PCB level as close to the IMU device as possible. If there is a source of acceleration or vibration in the vicinity of the MEMS device, we recommend testing on the PCB with a vibrometer to confirm that the MEMS device is not being excited by any resonance frequency.

### 3.9 EPOXY-SEAL AND OTHER MATERIAL

Please make sure that the sensor is not partially or fully covered and not in contact with any epoxy coating or other material. Direct contact with the sensor should be avoided so that the sensor would not show any unexpected output because of this. The contact material includes any type of material.

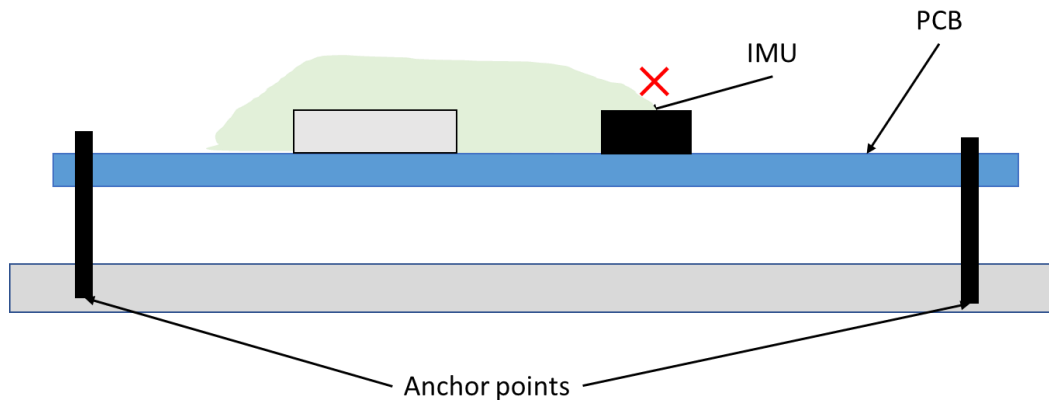
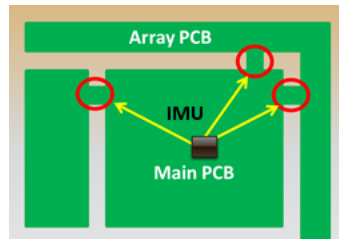

Figure 16. Keep distance from epoxy coating



### 3.10 EDGE OF PCB

Keep the IMU device away from the edge of the PCB or bridges for PCB separation by router (see picture below). Deflection from a routing drill or saw can damage the MEMS device. Similarly, dull router bits and saw blades can cause excessive mechanical vibration, which should be avoided. Do not snap apart panelized boards, since snapping apart the PCB boards may introduce severe bending forces and mechanical shock, which may damage the IMU device.



**Figure 17. Panelized PCB Bridges**

## 4 IMU PRODUCTS HANDLING GUIDELINE

### 4.1 MEMS HANDLING INSTRUCTIONS

Unlike conventional IC products in similar packages, MEMS devices contain moving micromechanical structures. Therefore, MEMS devices require different handling precautions than conventional ICs prior to mounting onto PCBs.

All TDK InvenSense IMU products react negatively to Helium gas.

TDK InvenSense products have been qualified to an unpowered shock tolerance of 10,000g or 20,000g. Information for each component is available in the corresponding product datasheet. Furthermore, the products are shipped in cushioned tape and reel packing (ref.: EIA-481) to protect them from potential damage induced by abnormal handling and shipping.

- Do not drop individually packaged sensors or trays of sensors. Components placed in trays could be subject to excessive *g*-forces and stress.
- PCBs that incorporate mounted sensors should not be separated by manually snapping them apart. This could create excessive *g*-forces and stress.
- Do not clean MEMS sensors in ultrasonic baths. Ultrasonic baths can induce MEMS damage if the bath energy causes excessive drive motion through resonant frequency coupling.
- Do not open and remove MEMS devices from the moisture barrier bag until you are ready to use them. The moisture barrier bag provides protection to the MEMS sensors during storage and transfer.
- Do not use any devices that are dropped inadvertently during handling.

### 4.2 IMU PRODUCTS ASSEMBLY GUIDELINES

Any material used in the surface mount assembly process of the MEMS gyroscope should be free of restricted RoHS elements or compounds. Pb-free solders should be used for assembly.

Although the sensor products can withstand up to three reflow soldering cycles, it is strongly recommended to avoid multiple reflow steps for the MEMS component. The PCB side where the MEMS is placed must be soldered the last.

Use a typical pick-and-place machine with reflow equipment like an oven. Avoid any manual soldering process. Machines should be set to the lowest and slowest pick and place operations, as much possible, to help minimize any shock impact to the device.

The sensor has been designed and tested to survive shock up to the Absolute Maximum Rating (AMR) reported into the datasheet. Shock above the AMR could damage the MEMS structure. Parts subjected to shock greater than AMR must be discarded.

### 4.3 ESD CONSIDERATIONS

Establish and use (Electrostatic Damage) ESD-safe handling precautions when unpacking and handling ESD-sensitive devices.

- Store ESD-sensitive devices in ESD-safe containers until ready for use. The tape and reel moisture-sealed bag is an ESD approved barrier. The best practice is to keep the units in the original moisture sealed bags until ready for assembly.
- TDK InvenSense products are qualified to meet HBM (Human Body Model) 2000V and CDM (Charged Device Model) 500V. Restrict all device handling to ESD protected work areas that measure less than 200V static charge. Ensure that all workstations and personnel are properly grounded to prevent ESD.

#### 4.4 REFLOW SPECIFICATION

TDK InvenSense products are qualified in accordance with IPC/JEDEC J-STD-020. This standard classifies proper packaging, storage, and handling to avoid subsequent thermal and mechanical damage during the solder-reflow attachment phase of PCB assembly.

The peak-solder reflow temperature for package qualification is 260°C maximum for IMU products. The TDK InvenSense products can withstand up to three reflow soldering cycles.

#### 4.5 STORAGE SPECIFICATIONS

TDK InvenSense products conform to the storage specifications of IPC/JEDEC J-STD-020 Moisture Sensitivity Level (MSL) 1.

Calculated shelf-life in moisture-sealed bag	12 months -- Storage Conditions: <40°C and <90% RH
After opening moisture-sealed bag	Unlimited hours -- Storage Conditions: Ambient ≤30°C at 85%RH

TDK InvenSense products conform to the storage specifications of IPC/JEDEC J-STD-020 Moisture Sensitivity Level (MSL) 3.

Calculated shelf-life in moisture-sealed bag	12 months -- Storage Conditions: <40°C and <90% RH
After opening moisture-sealed bag	168 hours -- Storage Conditions: Ambient ≤30°C at 60%RH

TDK InvenSense products conform to the storage specifications of IPC/JEDEC J-STD-020 Moisture Sensitivity Level (MSL) 5.

Calculated shelf-life in moisture-sealed bag	12 months -- Storage Conditions: <40°C and <90% RH
After opening moisture-sealed bag	48 hours -- Storage Conditions: Ambient ≤30°C at 60%RH

**Notes:** A attain the MSL rating for motion-based products, please refer to the qualification report for the details.

#### 4.6 TAPE AND REEL HANDLING INSTRUCTIONS

TDK InvenSense IMU devices are shipped in tape and reels. They are packaged to protect them from potential damage induced by normal handling and shipping. These are handling guidelines for the tape and reels populated with MEM's motion devices:

- Tape and reels (with devices) should not be dropped at any time or un-reeled manually.
- Precautions should be taken to minimize the amount of vibration that tape and reels (with devices) are subjected to while in pick and place machines.
- The slowest settings possible should be used on pick and place machines during the SMT process.
- Tape and reels should be kept in packaging for as long as possible, until ready for use on pick and place machines
- Any carts used for internal transportation of tape and reels (with devices) should be padded with bumpers and have shock absorbing features.

## 4.7 TAPE AND REEL PACKAGING

Please refer to each product's datasheet for IMU product Pin-1 orientation in tape.

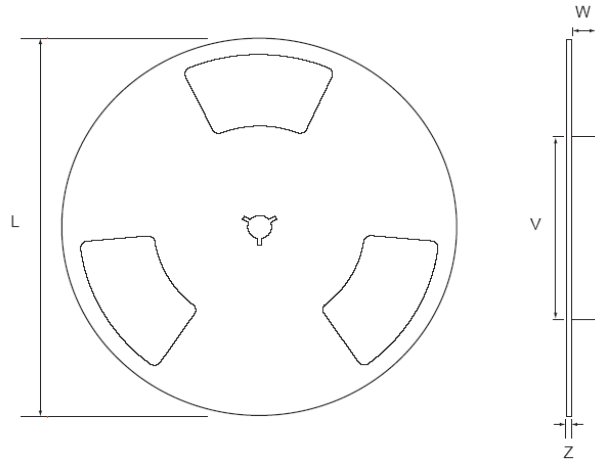

Figure 18. Reel Outline Drawing

REEL (mm)			
L	V	W	Z
330	102	12.8	2.3

Table 1. Reel Dimensions



Figure 19. Barcode Label

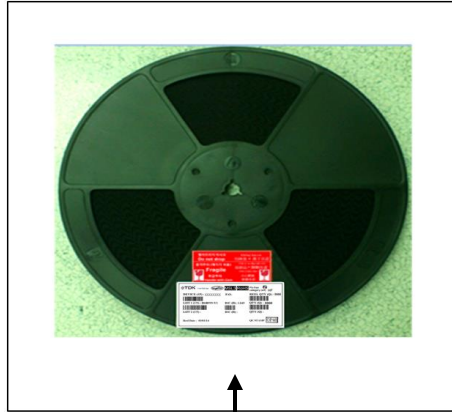

Figure 20. Location of Label on Reel



Figure 21. Barcode Label on the Left of the Box

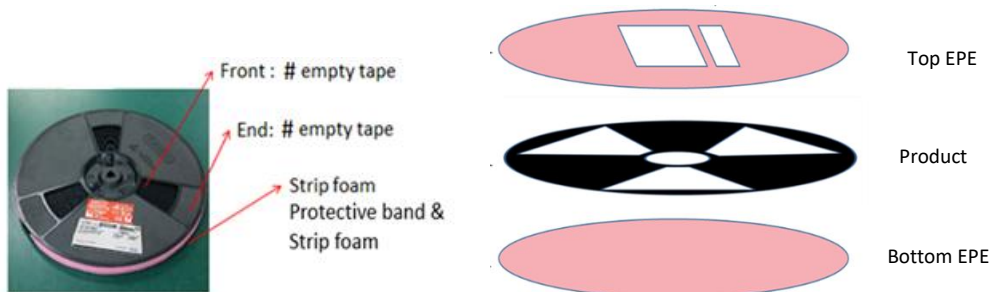



Figure 22. REEL Packing

<div style="display: flex; justify-content: space-between; align-items: center;"> <div style="text-align: center;">  <p><b>CAUTION</b> This bag contains <b>MOISTURE-SENSITIVE DEVICES</b></p> </div> <div style="text-align: center;"> <p><b>LEVEL</b></p> <div style="border: 1px solid black; padding: 2px 10px; width: 30px; margin: 0 auto;">1</div> </div> </div> <p style="font-size: small; text-align: right;">If Blank, see adjacent bar code label</p> <ol style="list-style-type: none"> <li>1. Calculated shelf life in sealed bag: 12 months at &lt; 40 °C and &lt; 90% relative humidity (RH)</li> <li>2. Peak package body temperature: <u>Not to exceed 260</u> °C</li> <li>3. After bag is opened, devices that will be subjected to reflow solder or other high temperature process must             <ol style="list-style-type: none"> <li>a) Mounted within: <u>unlimited</u> hours of factory conditions ≤ 30 °C/85% RH, OR</li> <li>b) Stored per J-STD-033</li> </ol> </li> <li>4. Devices require bake, before mounting, if:             <ol style="list-style-type: none"> <li>a) Humidity Indicator Card is &gt; 10% when read at 23 ± 5 °C</li> <li>b) 3a or 3b not met.</li> </ol> </li> <li>5. If baking is required, refer to IPC/JEDEC J-STD-033 for bake procedure</li> </ol> <p style="font-size: x-small;">Note: If device containers cannot be subjected to high temperature or shorter bake times are desired, reference IPC/JEDEC J-STD-033 for bake procedure</p> <p>Bag Seal Date: _____ <small>If Blank, see adjacent bar code label</small></p> <p style="font-size: x-small;">Note: Level and body temperature defined by IPC/JEDEC J-STD-020</p>	<div style="display: flex; justify-content: space-between; align-items: center;"> <div style="text-align: center;">  <p><b>CAUTION</b> This bag contains <b>MOISTURE-SENSITIVE DEVICES</b></p> </div> <div style="text-align: center;"> <p><b>LEVEL</b></p> <div style="border: 1px solid black; padding: 2px 10px; width: 30px; margin: 0 auto;">3</div> </div> </div> <p style="font-size: small; text-align: right;">If Blank, see adjacent bar code label</p> <ol style="list-style-type: none"> <li>1. Calculated shelf life in sealed bag: 12 months at &lt; 40° C and &lt; 90% relative humidity (RH)</li> <li>2. Peak package body temperature: <u>Not to exceed 260</u> °C</li> <li>3. After bag is opened, devices that will be subjected to reflow solder or other high temperature process must             <ol style="list-style-type: none"> <li>a) Mounted within: <u>168</u> hours of factory conditions ≤ 30 °C/60% RH, or</li> <li>b) Stored per J-STD-033</li> </ol> </li> <li>4. Devices require bake, before mounting, if:             <ol style="list-style-type: none"> <li>a) Humidity Indicator Card reads &gt;10% for level 2a-5a devices or &gt;60% for level 2 devices when read at 23± 5 °C</li> <li>b) 3a or 3b are not met</li> </ol> </li> <li>5. If baking is required, refer to IPC/JEDEC J-STD-033 or bake devices for <u>9</u> hours at 125 ± 5 °C in trays or in Tape-and-Reel bake devices for <u>312</u> hours at 40 °C, ≤ 5% RH</li> </ol> <p>Bag Seal Date: _____ <small>If Blank, see adjacent bar code label</small></p> <p style="font-size: x-small;">Note: Level and body temperature defined by IPC/JEDEC J-STD-020</p>
-------------------------------------------------------------------------------------------------------------------------------------------------------------------------------------------------------------------------------------------------------------------------------------------------------------------------------------------------------------------------------------------------------------------------------------------------------------------------------------------------------------------------------------------------------------------------------------------------------------------------------------------------------------------------------------------------------------------------------------------------------------------------------------------------------------------------------------------------------------------------------------------------------------------------------------------------------------------------------------------------------------------------------------------------------------------------------------------------------------------------------------------------------------------------------------------------------------------------------------------------------------------------------------------------------------------------------------------------------------------------------------------------------------------------------------------------------------------------------------------------------------------------------------------------------------------------------------------------------------------------------------------------------------------------------------------------------------------------------------------------------------------------------------------	---------------------------------------------------------------------------------------------------------------------------------------------------------------------------------------------------------------------------------------------------------------------------------------------------------------------------------------------------------------------------------------------------------------------------------------------------------------------------------------------------------------------------------------------------------------------------------------------------------------------------------------------------------------------------------------------------------------------------------------------------------------------------------------------------------------------------------------------------------------------------------------------------------------------------------------------------------------------------------------------------------------------------------------------------------------------------------------------------------------------------------------------------------------------------------------------------------------------------------------------------------------------------------------------------------------------------------------------------------------------------------------------------------------------------------------------------------------------------------------------------------------------------------------------------------------------------------------------------------------------------------------------------------------------------------------------------------------------------------------------------------------------



**CAUTION**  
This bag contains  
**MOISTURE-SENSITIVE DEVICES**

**LEVEL**

5

If Blank, see adjacent bar code label

1. Calculated shelf life in sealed bag: 12 months at < 40° C and < 90% relative humidity (RH)
2. Peak package body temperature: Not to exceed 260 °C
3. After bag is opened, devices that will be subjected to reflow solder or other high temperature process must
  - a) Mounted within: 48 hours of factory conditions ≤ 30 °C/60% RH, or
  - b) Stored per J-STD-033
4. Devices require bake, before mounting, if:
  - a) Humidity Indicator Card is > 10% when read at 23 ± 5 °C
  - b) 3a or 3b are not met
5. If baking is required, devices may be baked for 12 hours at 125 ± 5 °C

Note: If device containers can not be subjected to high temperature or shorter bake times and desired, reference IPC/JEDEC J-STD-033 for bake procedure

Bag Seal Date: \_\_\_\_\_  
If Blank, see adjacent bar code label

Note: Level and body temperature defined by IPC/JEDEC J-STD-020

Figure 23. MSL Label (MSL 1, MSL 3 and MSL 5)



Figure 24. Reel Packing for shipping



Caution Label



ESD Label

Figure 25. Labels



Standard Packing Box



Boxes Placed in Foam-Lined Shipper Box



Outer Shipper Label

Figure 26. Boxes and Labels

Representative Shipping Carton Label:

<b>E4</b>		<b>Delivery Name NO:</b>	
<b>TDK</b> InvenSense		<b>4509027</b>	
<b>From:</b> InvenSense Taiwan Ltd. IF,9 Prosperity 1st Road,Hsinchu Science Park, Hsinchu City,30078,Taiwan TEL: +886 3 6680999 FAX: +886 3 6686777		<b>Ship To:</b> Samsung SAMSUNG VIETNAM Yen Trun Dist., Bac Ninh province,,VN	
SUPP PROD ID: XXXXXXXX			
LOT#: QWV966-LC3 QTY: 5000 LOT#: QTY: 0 LOT#: QTY: 0 LOT#: QTY: 0	LOT#: QTY: 0 LOT#: QTY: 0 LOT#: QTY: 0		
Total Quantity/Carton: 5000 		Weight : (KG) 2.89 	
Pb-free	Shipping Carton:	Category (e4) HF	
<b>MSL1</b> <b>RoHS</b>	1	OF	1

Figure 27. Outer Shipping Carton Label



## 5 REVISION HISTORY

REVISION DATE	REVISION	DESCRIPTION
11/01/2022	1.0	Initial release
12/22/2022	1.1	Cosmetic updates
09/15/2023	1.2	Updated section 2.2, added QFN package PCB land pattern Updated section 4 and rest of the document to cover all IMU Products
12/06/2023	1.3	Changed chapter 3 title. Updated chapter 4.1 and 4.2
01/29/2024	1.4	Updated introduction chapter 1, and legal information; and fixed typo in the footer

This information furnished by InvenSense or its affiliates (“TDK InvenSense”) is believed to be accurate and reliable. However, no responsibility is assumed by TDK InvenSense for its use, or for any infringements of patents or other rights of third parties that may result from its use. Specifications are subject to change without notice. TDK InvenSense reserves the right to make changes to this product, including its circuits and software, in order to improve its design and/or performance, without prior notice. TDK InvenSense makes no warranties, neither expressed nor implied, regarding the information and specifications contained in this document. TDK InvenSense assumes no responsibility for any claims or damages arising from information contained in this document, or from the use of products and services detailed therein. This includes, but is not limited to, claims or damages based on the infringement of patents, copyrights, mask work and/or other intellectual property rights.

Certain intellectual property owned by InvenSense and described in this document is patent protected. No license is granted by implication or otherwise under any patent or patent rights of InvenSense. This publication supersedes and replaces all information previously supplied. Trademarks that are registered trademarks are the property of their respective companies. TDK InvenSense sensors should not be used or sold in the development, storage, production, or utilization of any conventional or mass-destructive weapons or for any other weapons or life-threatening applications, as well as in any other life critical applications such as medical equipment, transportation, aerospace and nuclear instruments, undersea equipment, power plant equipment, disaster prevention and crime prevention equipment.

©2022–2024 InvenSense. All rights reserved. InvenSense, SmartMotion, SmartIndustrial, SmartSonic, SmartAutomotive, SmartRobotics, SmartSound, SmartPressure, MotionProcessing, MotionProcessor, UltraPrint, MotionTracking, CHIRP Microsystems, SmartBug, SonicLink, Digital Motion Processor, AAR, and the InvenSense logo are registered trademarks of InvenSense, Inc. The TDK logo is a trademark of TDK Corporation. Other company and product names may be trademarks of the respective companies with which they are associated.



©2022-2024 InvenSense. All rights reserved.